

Clean Cycle™ 125kW Waste Heat to Electricity Generator

Stop wasting heat.

The Clean Cycle system captures wasted heat and turns it into electricity that you can use or sell back to the grid.

For the first time, small-scale installations can benefit from proven Organic Rankine Cycle technology to recapture lost energy and turn it into money. The Clean Cycle captures heat from a wide range of systems including engines, boilers, industrial heat stacks and solar thermal installations. Typical payback periods for applications like these range from 18 to 36 months.

Optimized Rankine Technology™

The Clean Cycle™ 125 integrates proven technologies into a unique, highly efficient system design. Key innovations include:

- Integrated power module, a high-speed turbine expander (26,500 rpm) plus high-efficiency alternator in one sealed unit. Only one moving part. No external seals. No gearbox.
- Super-efficient magnetic bearings with self-centering. No metal-on-metal. No oil systems.
- Sophisticated power electronics to turn the high-frequency output into utility-grade power. Power factor is 1, so no expensive capacitors.

Clean Cycle™ configurations

- The Clean Cycle™ S Series
GE's power module provided on a frame for integration by our approved distributors and integrators.
- The Clean Cycle™ P Series
A pre-packaged system for immediate installation; pre-configured with the right condenser and evaporator for each application.

The benefits

- Cleaner energy with no fuel needed
- Zero emissions
- Proven ORC technologies
- High-speed, high-efficiency power module
- Simple synchronization with utility
- Small-footprint packaged unit: ready to integrate
- High reliability, very low maintenance and ownership costs
- Modular and scalable design
- Fast payback

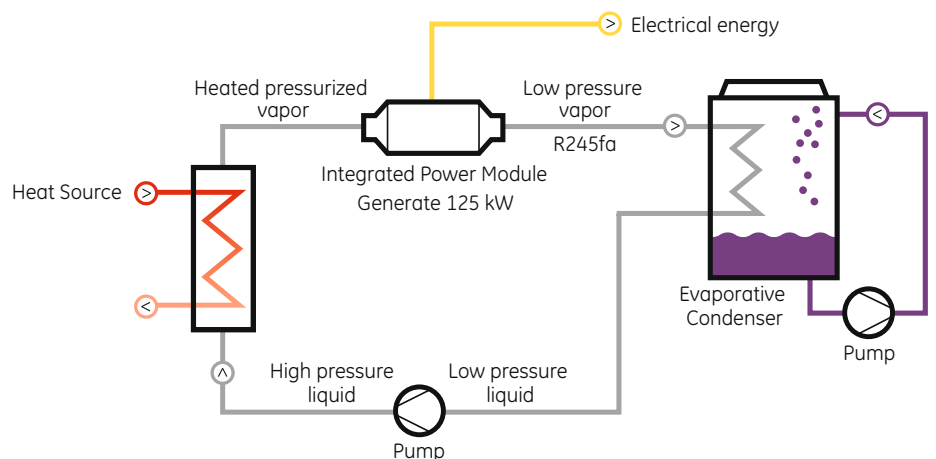

GE Power & Water Heat Recovery Solutions

Component Design

Alternator	High speed, permanent magnet
Turbine	Single stage radial expander turbine
Bearings	Magnetic frictionless
Design Standards	Yes
Piping	ASME B31.1
Heat Exchangers	ASME VIII/PED
Electrical Enclosures	NEMA1/ IP23

Clean Cycle™ 125 Performance Parameters

Electrical Output Gross 125kW

Waste Heat Conditions

Evaporation Temp	250°F	121°C
Input Energy	3,340,000 BTU/hr	980kW

Condensing in ISO Ambient: 59°F (15°C) 60% RH

Temp	70°F	21°C
Condensing Load	2,800,000 BTU/hr	821kW

Pressurized Hot Water to Power

Electrical Output Gross 125kW

Waste Heat Conditions

Inlet Temp	290°F	143°C
Outlet Temp	260°F	127°C
Flow Rate	119,555 lbm/hr	54,343 kg/hr

Condensing temperature of 70°F (21°C) and heat exchanger 95% efficient.

The technological strength of GE Power & Water's Heat Recovery Solutions division lies in the generation of power from waste heat within the low power range. The innovative Clean Cycle™ 125kW generator that produces emission-free power from waste heat emitted by various engine types and biomass boilers was developed under the guidance of an experienced and dynamic management team.

System

Refrigerant	R245fa (Non-ozone depleting)
Controls	PLC based
Remote Monitoring	Web based gateway
Operation	Designed for local & remote control
Packaged Solutions	Available

Saturated Steam to Power

Electrical Output Gross 125kW

Temperature	255°F	124°C
Pressure	32 psia	220.6 kPa
Flow	3,692 lbm/hr	1,678 kg/hr

1. Waste heat operating conditions: no superheat in steam included.
Condensing temperature of 70°F (21°C) and heat exchanger 95% efficient.

Hot Gases to Power

Electrical Output Gross 125kW

Inlet Temp		Flow Rate	
°F	°C	lbm/hr	kg/hr
400	204	150,000	68,182
500	260	75,000	34,091
600	316	49,500	22,500
700	371	36,900	16,773
800	427	29,250	13,295
900	482	24,250	11,023

1. Waste heat conditions – Exhaust gas temperature reduced to 300°F (149°C) with condensing temperature of 70°F (21°C)

2. Assumed exhaust gas Cp = 0.25 Btu/lbm - °F (1.05 kJ/kg - °C)

3. Heat exchanger 95% efficient

Talk to us.

**GE Power & Water
Heat Recovery Solutions**
2901 S.E. Monroe Street
Stuart, Florida 34997, USA
T: +1-772-219-9449

European Office
T: +44 1666 822 482

tony.hynes@ge.com
www.geheatrecovery.com



GE imagination at work